

BEHIND THE SMART WORLD

ART MEETS RADICAL OPENNESS
ART LAB 2015

WHAT IS THE VALUE OF DISPOSED DATA?

Thursday, May 21st, 19:00-22:00
at KunstRaum Goethestrasse xtd

Introduction:

Linda Kronman & Andreas Zingerle (KairUs)

Speakers:

Can Sinirtas (ECS Global, data rescue)

Uwe Sailer (data forensics)

Fieke Jansen (Tactical Technology Collective,
data brokers)

ARTISTS PRESENTATIONS: EXPLORING HARD DRIVES

Friday, May 22nd, 17:00-22:00
at KunstRaum Goethestrasse xtd

Artists:

Emöke Bada (Hungary)

Lilian Beidler (Switzerland)

Joakim Blattman (Norway)

Simon Krenn (Austria)

Fabian Kühfuss (Germany)

Marit Roland (Norway)

Matthias Urban (Austria)

Michael Wirthig (Austria)

Pim Zwier (Netherlands)

Organized by: kairus.org and servus.at

Website: research.radical-openness.org

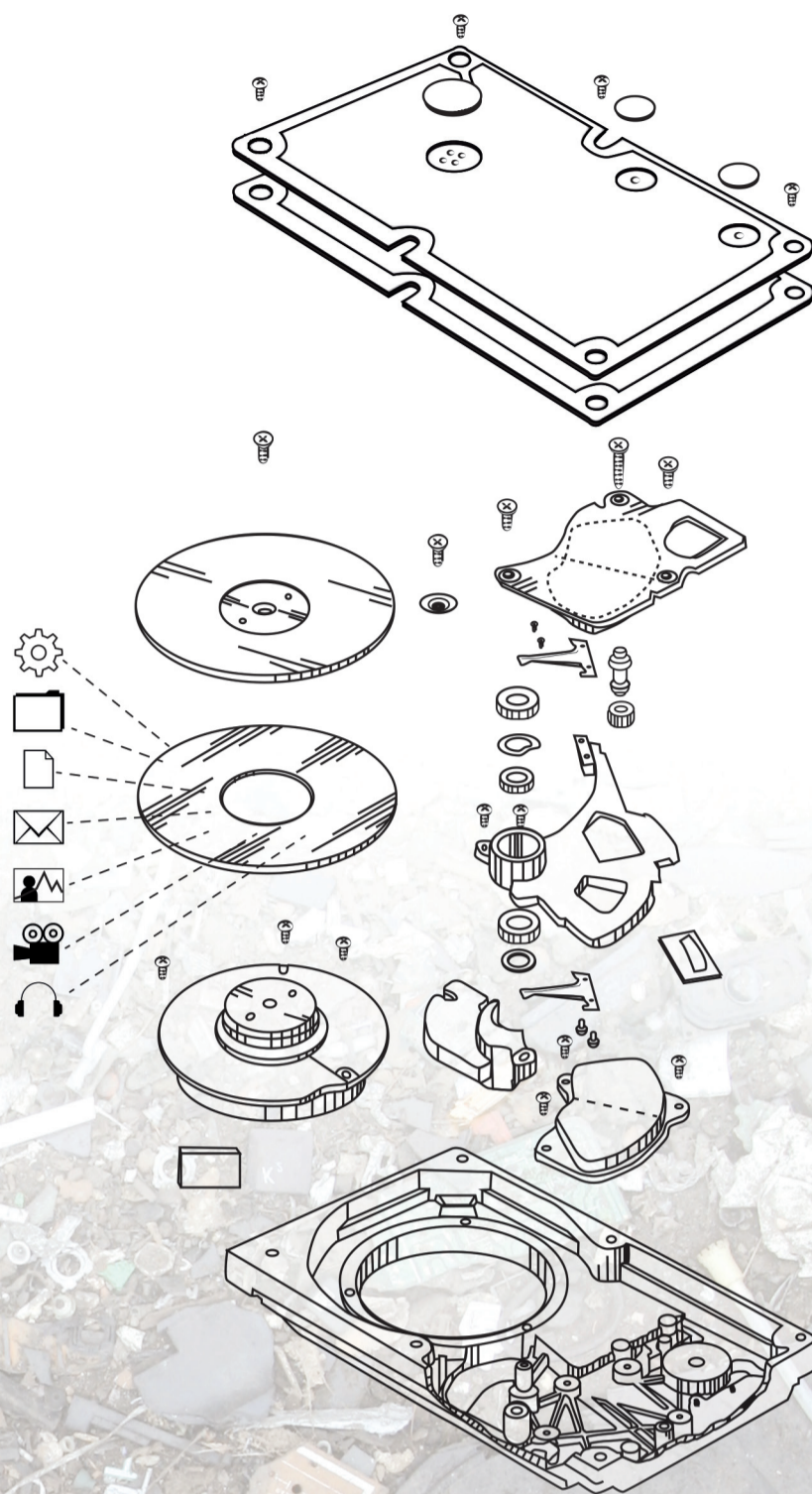

In today's smart world everything is saved, and growing datasets become increasingly hard to manage. Data that has been migrated or not accessed is forgotten on old storage mediums. Once discarded, electronics start their journey as waste, containing digital traces of us. Electronic remains become landfill, some transform into toxic wastelands such as Agbogbloshie in Ghana. Here our forgotten data resurface. How sensitive is the content of 22 hard-drives bought at Agbogbloshie? Can such data breaches expose individuals, companies or states? How realistic are these fears?

During the 'Behind-The-Smart-World' ArtLab, invited experts and artists explore these questions. Together with data recovery and forensic experts we discuss the value and sensitivity of data. Media artists evaluate disposed data and repurposed it for artistic installations, performances, sonifications, experimental videos or sculptures.

 **servus.at**
kunst & kultur im netz

KUNSTIP
KunstRaum Goethestrasse xtd

DATENRETTUNG

BUNDESKANZLERAMT  ÖSTERREICH